

FABRICACIÓN Y ALQUILER
**ANDAMIOS
COLGANTES
CERTIFICADOS**



El andamio colgante preferido por los
mamposteros



**NUEVO
PRODUCTO
2025**

**100% COMPATIBLE CON
LAS BARANDAS Y LAS
PLATAFORMAS DEL
ANDAMIO TIPO FECON**

ISO/IEC 17067:2013
ANSI A10.8:2019
NTC 2234: 1987
UNE-EN 1808:2016

BUREAU VERITAS
Certification



Trabaje seguro
con un sistema moderno,
certificado y con
DISEÑO DE INGENIERÍA



**DOBLE CABLE O
"GUAYA" DE
8.3MM
GALVANIZADA
CON ALMA**



**SISTEMA DE SEGURIDAD
DOBLE FRENO**

**APAREJO MANUAL
DE PALANCA
PARA FÁCIL
MANIPULACIÓN**

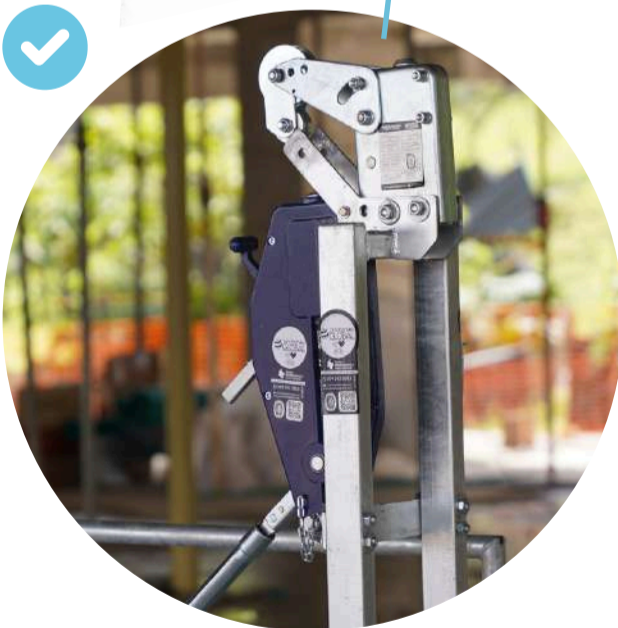

**SISTEMA DE ANCLAJE
CON CERTIFICACIÓN
INTERNACIONAL**

**TRABAJO SIN
LÍMITE DE ALTURA**

**GALVANIZADO EN CALIENTE
POR INMERSIÓN
+20 AÑOS DE DURABILIDAD**

**PLATAFORMA DE TRABAJO CONTINUO
DE 2,3,4 Y 5 METROS**

FACIL INSTALACIÓN

**CAPACIDAD DE CARGA
DE LA CANASTA DE
HASTA 380 Kg**

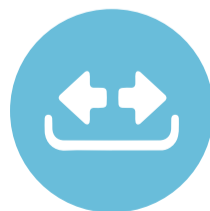
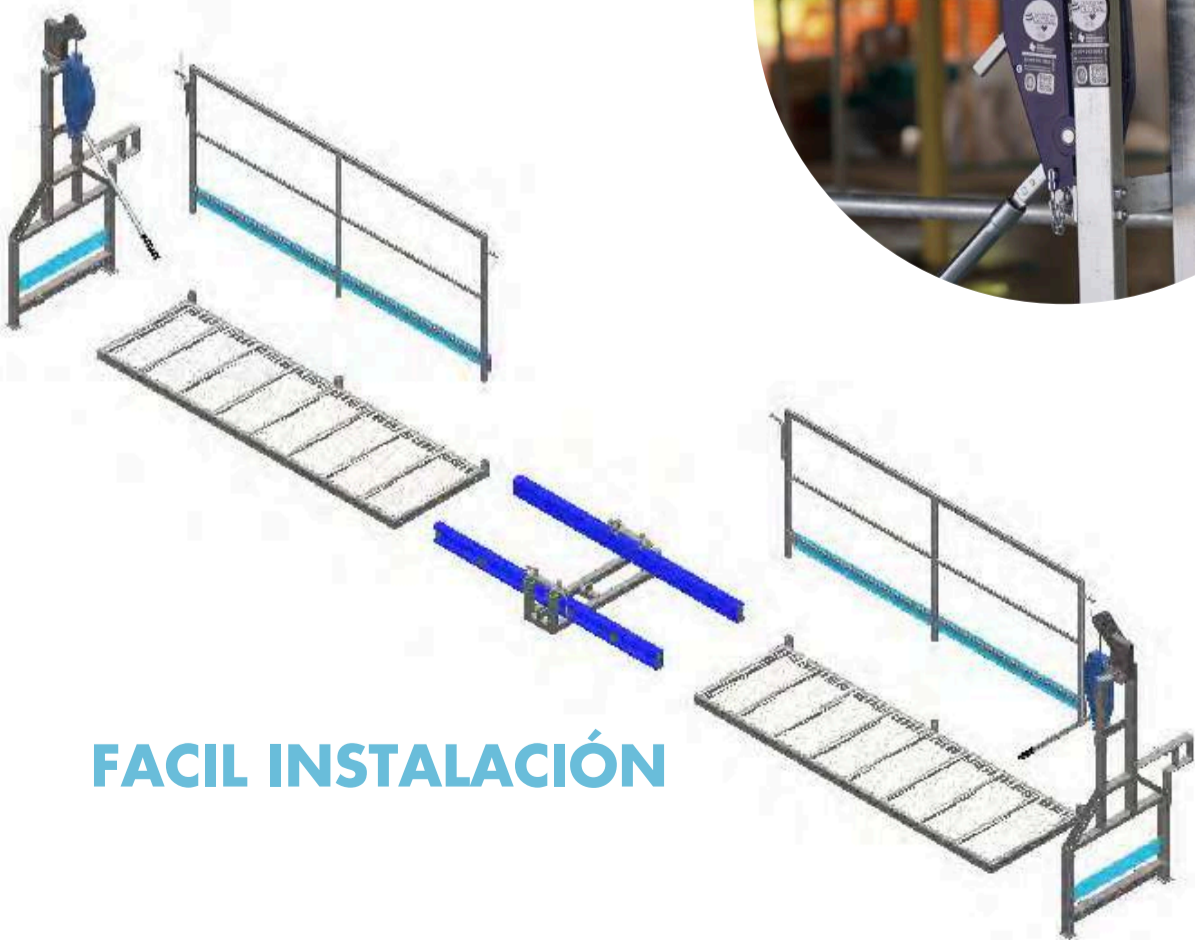

ANCLAJES A LA MEDIDA

Trabaje seguro en su andamio colgante con sistemas de sustentación certificados

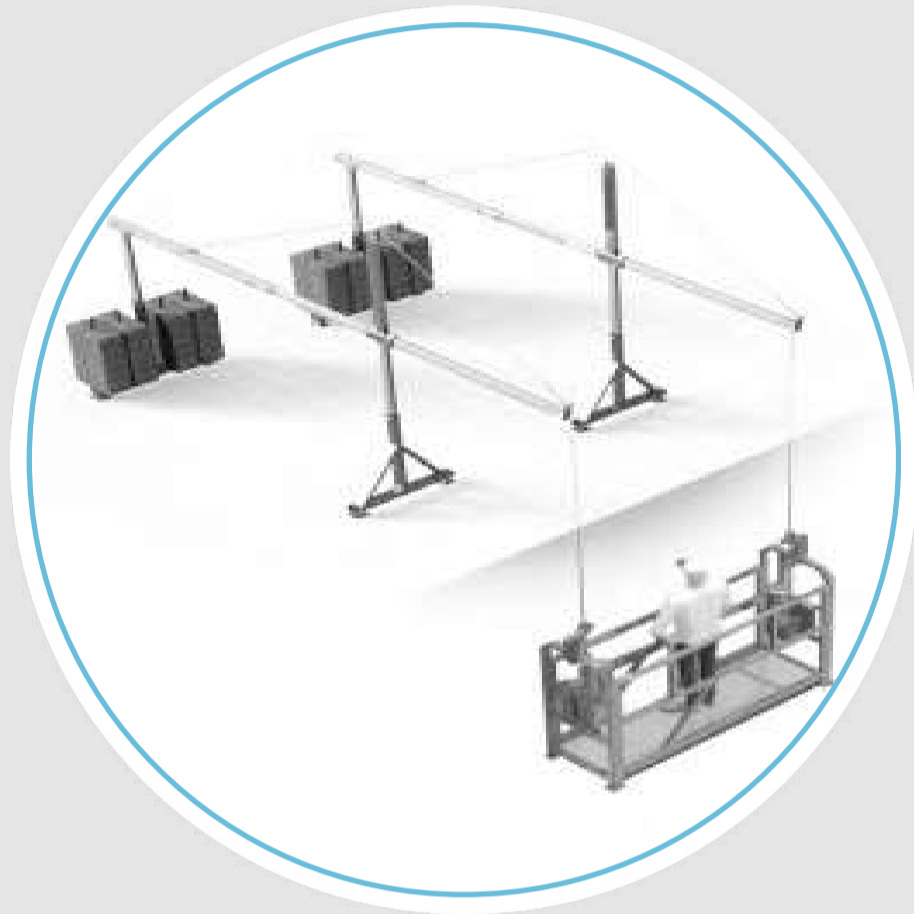

Telescópico rectangular contrapesado

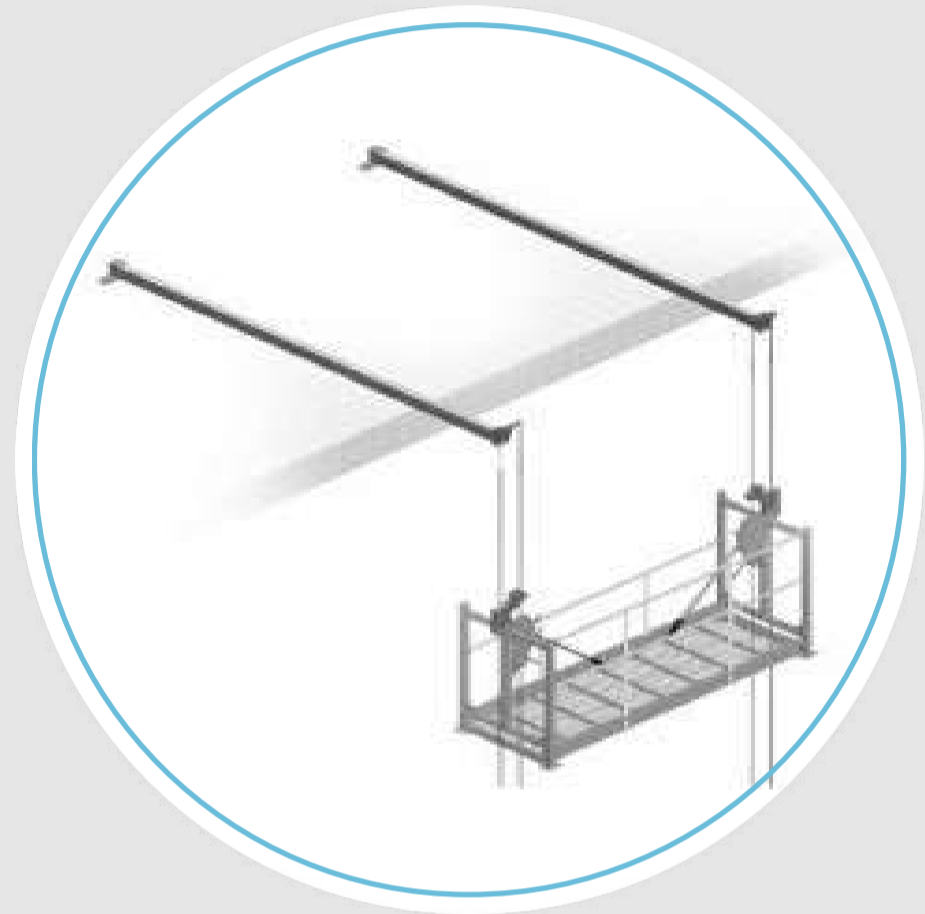

Anclaje a la losa de posición baja

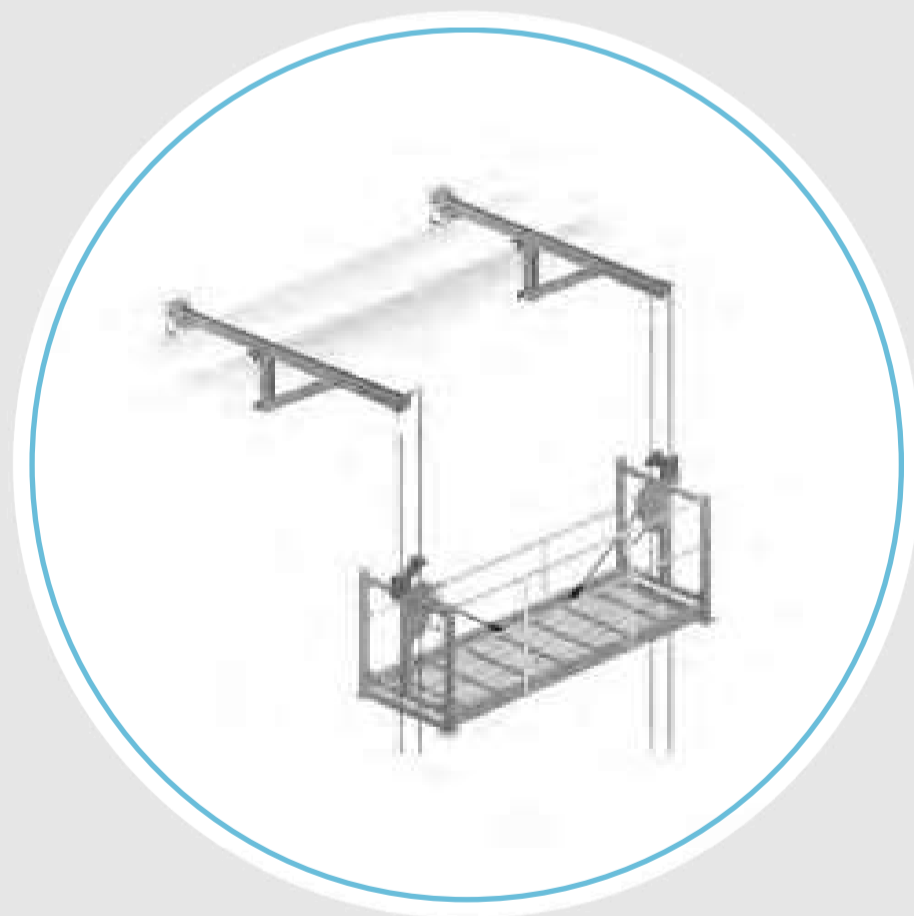

Pescante de antepecho tipo Clamp



Telescópico rectangular apuntalado





ANDAMIOS GLOBAL vs ANDAMIO TRADICIONAL

Descripción	Andamios Global	Andamio Tradicional
Plataformas (Capacidad de Carga Neta)	380 Kg	300 Kg
Liras (Capacidad de Carga)	800 Kg	300 Kg
Pescantes (Capacidad de Carga)	1.000 Kg	300 Kg
Cable	Diámetro 8.3mm	Diámetro 7.9mm
Acabado	Galvanizado	Pintura
Certificado	Bureau Veritas	No
Freno de Seguridad	Si	No
Modulación de Plataformas Continuas (solo dos liras)	Si	No
Altura Limitada por Guaya	No	Si
Sistema de Elevación	Palanca	Polea

CUMPLIMOS CON LA RESOLUCIÓN VIGENTE 4272 de 2021

(Requisitos Trabajo Seguro en Alturas)

YO  trabajar **SEGURO** en ALTURAS

Somos fabricantes



FELIPE TORO

Líder comercial

+57 316 878 4064

coordinacionoperaciones@andamiosglobal.com



(+57) 604 322 1019



WWW.ANDAMIOSGLOBAL.COM



CRA. 49A # 46A SUR - 04

ENVIGADO - COL